

FEATURES	APPLICATIONS
<ul style="list-style-type: none"> ±20ppm (Frequency Stability) Available Ceramic Package LVPECL Ultra Low Phase Jitter RoHS Compliant Tape and Reel 	<ul style="list-style-type: none"> Fiber Channel Gigabit Ethernet PCI Express



PART NUMBERING GUIDE	
<p>SUNTSU ULTRA LOW JITTER OSC → SUO 53 P 3 A 48 1 - 156.250M ← FREQUENCY (MHz)</p> <p>5.0mm x 3.2mm</p> <p>LVPECL</p> <p>SUPPLY VOLTAGE 3: 3.3V±5%</p> <p>FREQUENCY STABILITY A: ±50ppm B: ±30ppm C: ±25ppm *D: ±20ppm</p>	<p>TRI-STATE (ENABLE/ DISABLE) BLANK: No E/D 1: Pin 1</p> <p>OPERATING TEMPERATURE RANGE 07: 0°C to +70°C 16: -10°C to +60°C 17: -10°C to +70°C 27: -20°C to +70°C 38: -30°C to +85°C 48: -40°C to +85°C</p>
<p>Cage Code: 4GUT4 To customize your parameters contact a Suntsu representative. * For frequency stability option D contact a Suntsu representative</p>	

ELECTRICAL PARAMETERS	UNITS	MIN.	TYP.	MAX.	REMARKS
Frequency Range	MHz	80		170	
Frequency Stability (Includes Initial Tolerance at 25°C, Frequency Stability over Operating Temperature, Output Load Change, Supply Voltage Change, and First Year Aging at 25°C.)	ppm	-20		+20	See part numbering guide for options.
Operating Temperature	°C	-40		+85	See part numbering guide for options.
Storage Temperature		-55		+125	
Supply Voltage (V _{DD})	V	3.135	3.3	3.465	
Current (I _{DD})	mA			70	
Output Load (LVPECL)	Ω			50	50 Ω into V _{DD} -2.0V _{DC} .
Output Logic Levels	Output Logic High (V _{OH})	2.215		2.420	
	Output Logic Low (V _{OL})	1.470		1.745	
Rise (T _R) and Fall (T _F) Time	ns		0.4	0.6	Measured at 20% to 80% of Waveform.
Symmetry (Duty Cycle)	%	45	50	55	
Tri-State Input Voltage	Enable	0.7*V _{DD}			No Connection.
	Disable			0.3*V _{DD}	
Start-Up Time	ms			5	
Phase Jitter (12kHz ~ 20MHz)			0.077	0.1	150MHz~170MHz
			0.13	0.2	80MHz ~149MHz

OUTLINE DRAWING															
	<p>RECOMMENDED LAND PATTERN</p>														
<p>NOTE: Dimensions in millimeters (mm).</p>	<table border="1"> <thead> <tr> <th>PIN</th> <th>FUNCTION</th> </tr> </thead> <tbody> <tr> <td>1</td> <td>TRI-STATE or NC</td> </tr> <tr> <td>2</td> <td>NC</td> </tr> <tr> <td>3</td> <td>GND</td> </tr> <tr> <td>4</td> <td>OUTPUT</td> </tr> <tr> <td>5</td> <td>COMP OUTPUT</td> </tr> <tr> <td>6</td> <td>V_{DD}</td> </tr> </tbody> </table>	PIN	FUNCTION	1	TRI-STATE or NC	2	NC	3	GND	4	OUTPUT	5	COMP OUTPUT	6	V _{DD}
PIN	FUNCTION														
1	TRI-STATE or NC														
2	NC														
3	GND														
4	OUTPUT														
5	COMP OUTPUT														
6	V _{DD}														

TEST CIRCUIT (LVPECL)

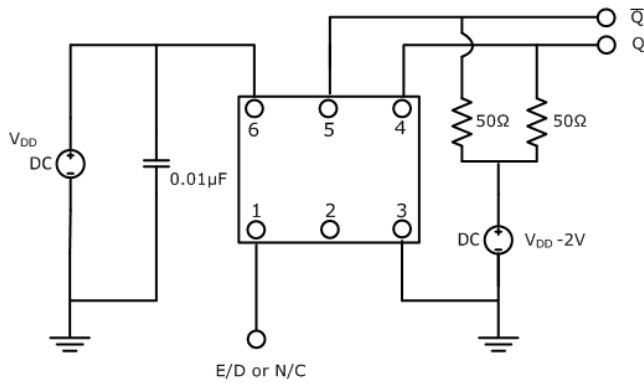

WAVEFORM (LVPECL)

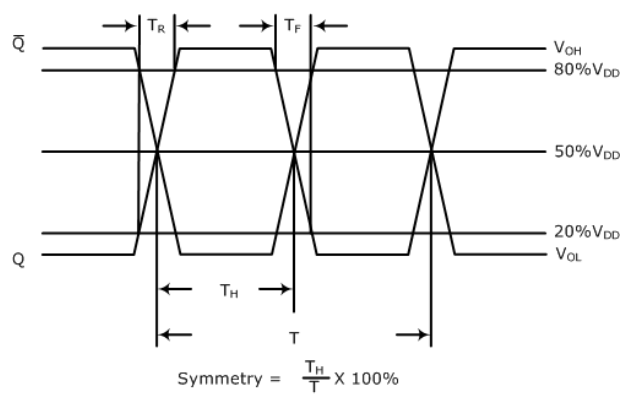

TYPICAL PHASE NOISE PERFORMANCE (MEASURED BY AGILENT E5052A)

Frequency 156.250MHz

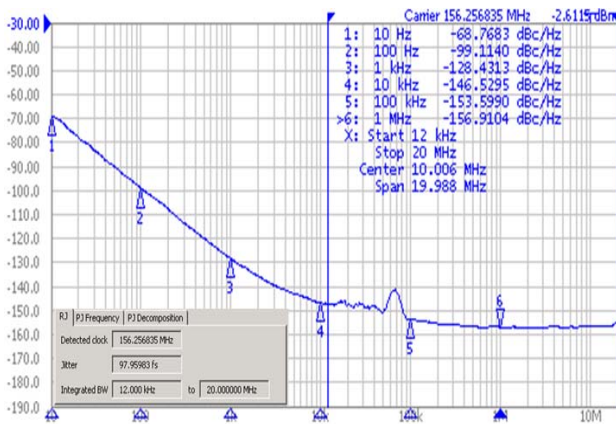

Frequency 156.250MHz

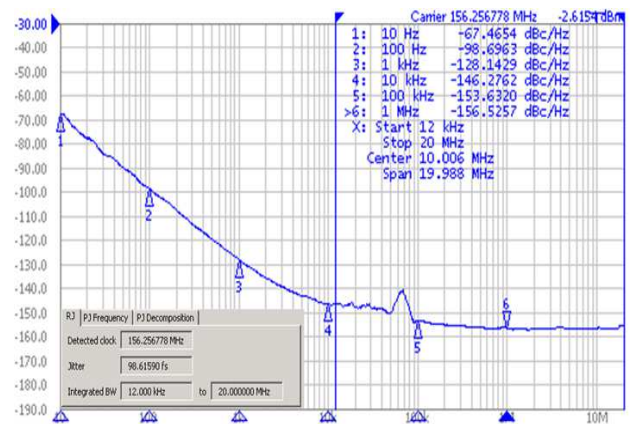

TYPICAL JITTER PERFORMANCE (MEASURED BY AGILENT E5052A)

Frequency 156.250MHz

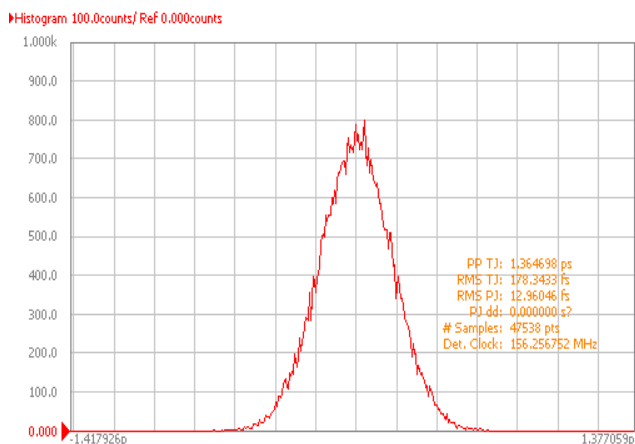

Frequency 156.250MHz

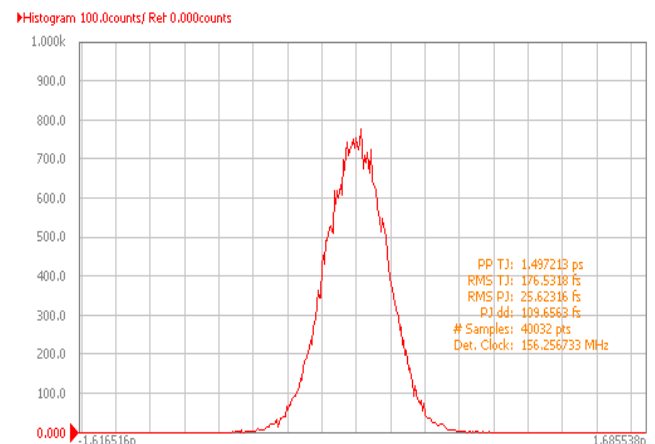

ENVIRONMENTAL & MECHANICAL SPECIFICATIONS

Temperature Cycling	MIL-STD-883, Method 1010, Condition B
Fine Leak Test	MIL-STD-883, Method 1014, Condition A
Gross Leak Test	MIL-STD-883, Method 1014, Condition C
Mechanical Shock	MIL-STD-883, Method 2002, Condition B
Vibration	MIL-STD-883, Method 2007, Condition A
Moisture Resistance	MIL-STD-883, Method 1004
Moisture Sensitivity	J-STD-020, MSL 1
Resistance to Soldering Heat	MIL-STD-202, Method 210, Condition K
Resistance to Solvents	MIL-STD-202, Method 215
Solderability	MIL-STD-883, Method 2003

REFLOW PROFILE

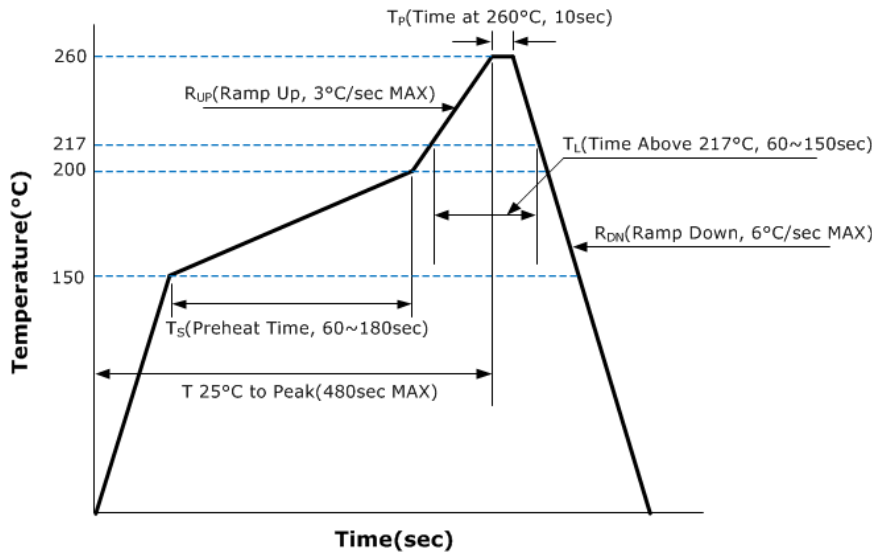

MARKING

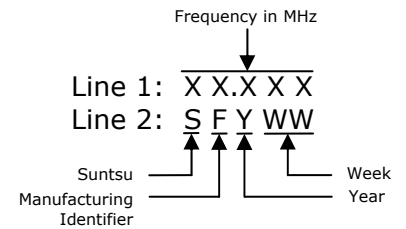

TAPE AND REEL DIMENSIONS

1,000pcs/reel

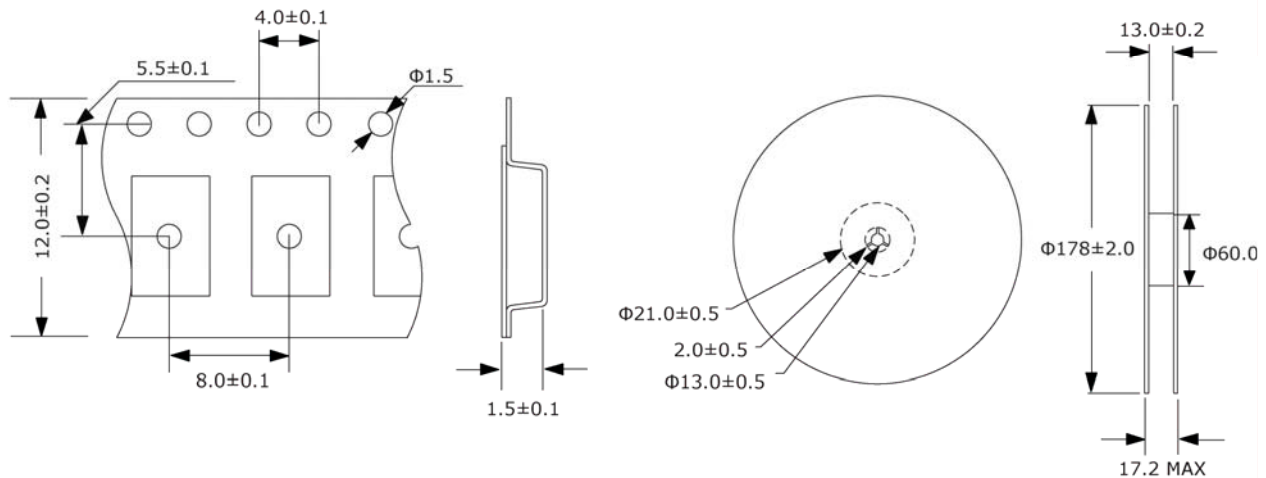

NOTE: Dimensions in millimeters (mm); drawing is not to scale.

REVISION RECORD

Rev. Number	Revision Description	Rev. Date	Manufacturing Identifier
Rev. 01	Initial release	Sep. 30, 2016	K